

UV LED dryer for curing flat objects, decorated substrates and color proofing

Designed for production, lab tests and R&D activities, ideal for the polymerization of inks, varnishes, adhesives and resins

Plug & Play

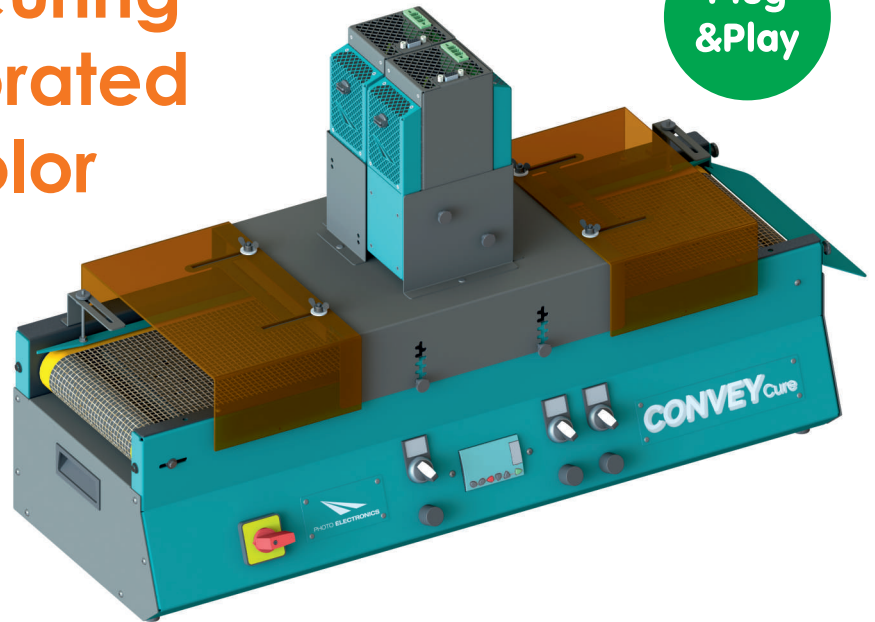

PLC with display for settings viewing

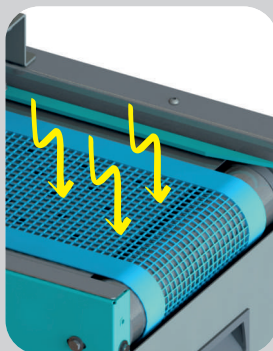

Vacuum table for holding light objects

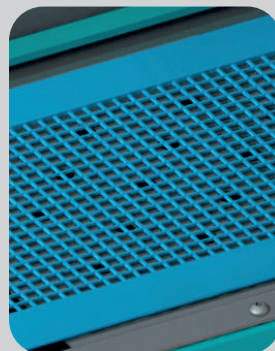

Perforated conveyor belt resistant to high temperatures

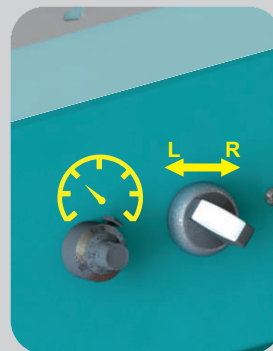

Adjustment of belt forward speed and direction

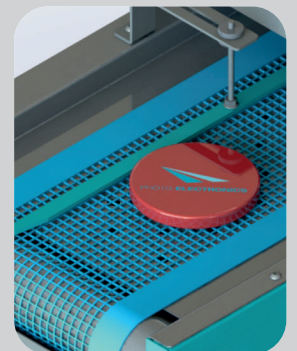

Removable and adjustable centering guides

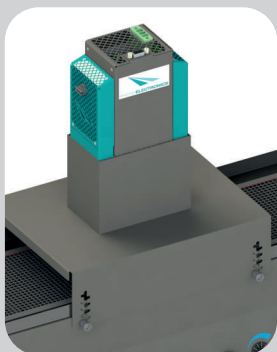

Tunnel with integrated lamp holder



Lamp height adjustment

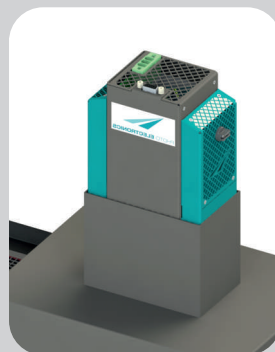

DROLED UV LED lamp with different wavelengths

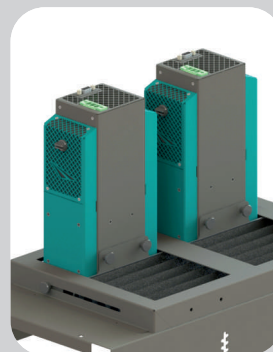

Possibility to install 2 DROLED UV LED lamps



Immediate lamp On/Off switching and intensity regulation



Installation of 1 or 2 DROLED UV LED lamps

CONVEY CURE is designed for the installation of one or two DROLED UV LED lamps L70, positioned side by side. The system is used for curing processes that require greater intensity or the presence of mixed wavelengths in the same system.

DROLED L70		
Flat Window or Focused Lens		
Wavelength peak	365nm	385 / 395 / 405nm
Irradiance peak	8 W/cm ²	8-12-16 W/cm ²
Emitting window width	80 mm	80 mm

Emitting window width
80 mm

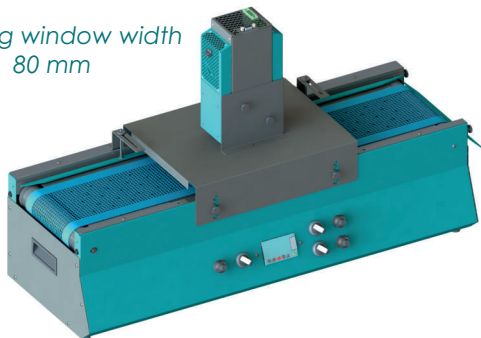

Emitting window width
160 mm (80+80)

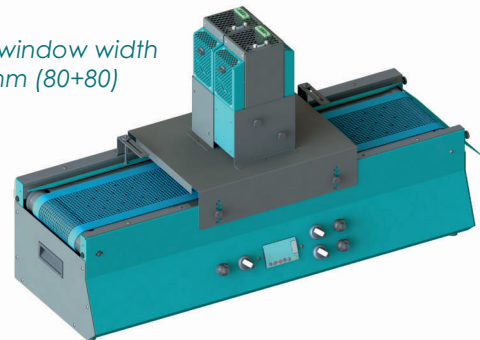

Conveyor belt with guides

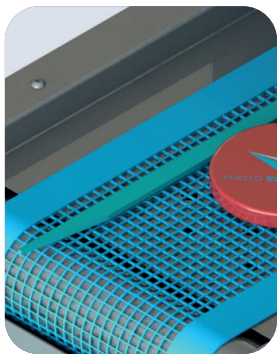

Teflon-coated glass fiber, resistant to UV radiation and perforated to allow aspiration and stabilization of light objects.

Adjustable and removable centering guides

Tunnel with lamp/s holder

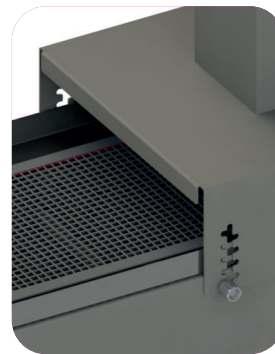

Integrated holder

Manual regulation of the lamp height with knobs, single steps of 5 mm

Fishbone system

Height Min 5 / Max 50 mm from the belt

Conveyor belt

5 Standard speeds or customized

Dryer model	mt/min
CONVEY800_02	0.2/2
CONVEY800_04	0.45/4.5
CONVEY800_10	1/10
CONVEY800_30	3/30
CONVEY800_50	5/50

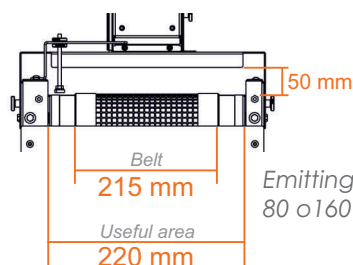

Dimensions

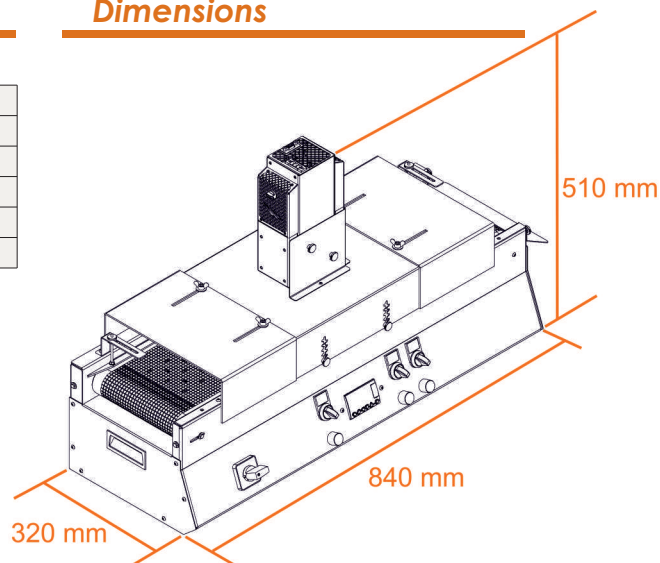

Electrical data

Consumption 1000W max
Universal multi-voltage power supply
110-277V / AC 50-60 Hz

Object to cure

H max 50 mm

Dryer weight

26 Kgs

